

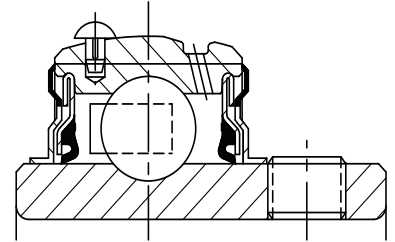

# SELECTION/DIMENSIONS

## Setscrew Ball Bearings SC NORMAL DUTY SCREW CONVEYOR HANGER BEARINGS



Lube Fitting Thread Size:  
1/8-27 NPT

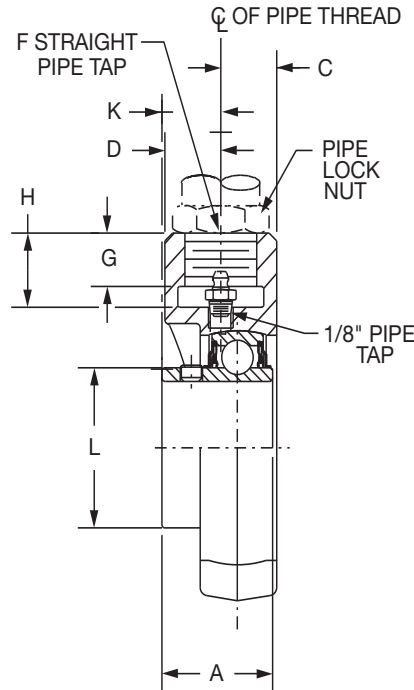
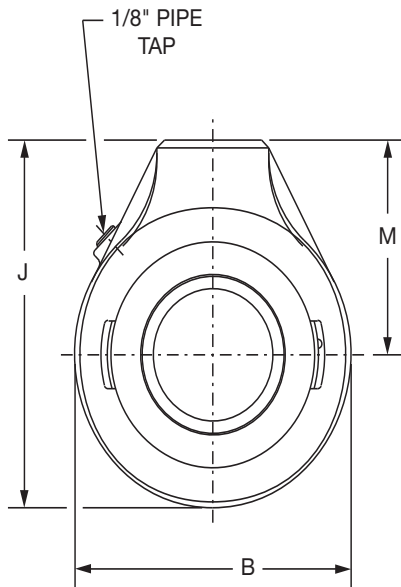

Series	Shaft Size	Part No.	Description
206	1	057878	SCHB-SC-100
	1-1/8	073287	SCHB-SC-102
207	1-3/16	057220	SCHB-SC-103
	1-1/4	124996	SCHB-SC-104
	1-3/8	058630	SCHB-SC-106
208	1-7/16	126049	SCHB-SC-107
	1-1/2	124290	SCHB-SC-108
	1-5/8	124404	SCHB-SC-110
210	1-11/16	124408	SCHB-SC-111
	1-3/4	124299	SCHB-SC-112
	1-15/16	124405	SCHB-SC-115
	2	124291	SCHB-SC-200
212	2-3/16	124409	SCHB-SC-203
	2-1/4	124419	SCHB-SC-204
	2-7/16	124292	SCHB-SC-207
216	2-15/16	124406	SCHB-SC-215
	3	124293	SCHB-SC-300
218	3-7/16	053320	SCHB-SC-307
	3-1/2	057361	SCHB-SC-308

@ Assembled to order

FEATURES/BENEFITS  
PAGE B4-3

HOW TO ORDER/NOMENCLATURE  
PAGE B4-5

SELECTION  
PAGE B4-6

ACCESSORIES  
PAGE B4-98

## SELECTION/DIMENSIONS



## Setscrew Ball Bearings

## SC NORMAL DUTY SCREW CONVEYOR HANGER BEARINGS

Bearing Reference Guide

ULTRA KLEEN

E-Z KLEEN

Extreme Duty

Setscrew Ball Bearing

GRIP TIGHT

D-LOK Ball Bearing

Series	Shaft Size	Weight lbs.	A	B	C	D	F*	G	H	J	K	L	M
206	1 1-1/8	3.0	1.52	3.13	0.53	1.03	3/4-14	0.75	0.94	4.06	0.89	1.57	2.50
207	1-3/16	3.5	1.71	3.88	0.82	0.82	3/4-14	0.63	0.94	4.69	0.98	1.84	2.75
	1-1/4	3.5											
	1-3/8	3.5											
208	1-7/16	3.4	1.94	4.00	0.83	0.83	3/4-14	0.63	0.94	4.88	1.02	2.05	2.88
	1-1/2	3.4											
	1-5/8	3.8											
210	1-11/16	5.4	1.94	4.63	0.94	1.78	1 - 11-1/2	0.81	1.13	5.56	0.91	2.43	3.25
	1-3/4	4.8											
	1-15/16	4.5											
	2	4.4											
212	2-3/16	5.0	2.31	5.50	1.16	1.78	1-1/4 - 11-1/2	1.13	1.44	6.75	1.07	2.97	4.00
	2-1/4	5.0											
	2-7/16	7.4											
216	2-15/16	14.0	2.38	7.00	1.36	1.45	1-1/2 - 11-1/2	1.25	1.69	8.38	1.17	3.83	4.88
	3	14.6											
218	3-7/16	21.2	2.56	8.31	1.76	1.74	2 - 11-1/2	1.75	2.19	10.16	1.39	4.35	6.00
	3-1/2	21.0											

Use straight thread for the pipe. Bearing to be secured with a heavy locknut

Pipe plug and lube fitting are factory installed and may be reversed from position shown

**NOTE:** Inserts use the ProGuard Plus (-FF) seals. 1, 1-3/16, 1-7/16, 1-11/16, 1-3/4, 2-3/16, 2-1/4  
2-15/16, 3, 3-7/16 & 3-1/2 use SCM inserts with flingers.

FEATURES/BENEFITS PAGE B4-3	HOW TO ORDER/NOMENCLATURE PAGE B4-5	SELECTION PAGE B4-6	ACCESSORIES PAGE B4-98
--------------------------------	--	------------------------	---------------------------

B4-85